

2004 ACCESSORIES & EQUIPMENT

Theft Deterrent - Vue

SCHEMATIC AND ROUTING DIAGRAMS

THEFT DETERRENT SYSTEM SCHEMATICS

Refer to Anti-Theft in System Wiring Diagrams .

COMPONENT LOCATOR

THEFT DETERRENT SYSTEM CONNECTOR END VIEWS

Passlock Sensor (Part of the Ignition Lock Cylinder Case) Connector End View

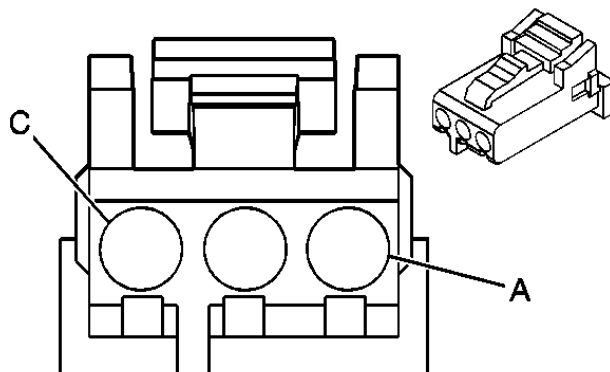

Connector Part Information		• 15326747 • 3-Way F Micro-Pack 064 (BK)	
Pin	Wire Color	Circuit Number	Function
A	RD/WH	812	12 Volt Reference
B	OG/BK	1057	Low Reference
C	YE	1836	Security System Sensor Signal

DIAGNOSTIC INFORMATION AND PROCEDURES

DIAGNOSTIC STARTING POINT - THEFT DETERRENT

Begin the system diagnosis with the **Diagnostic System Check - Theft Deterrent** . The Diagnostic System Check will provide the following information:

- The identification of the control module(s) which command the system
- The ability of the control module(s) to communicate through the serial data circuit
- The identification of any stored diagnostic trouble codes (DTCs) and their status

The use of the Diagnostic System Check will identify the correct procedure for diagnosing the system and where the procedure is located.

DIAGNOSTIC SYSTEM CHECK - THEFT DETERRENT

Test Description

The numbers below refer to the step numbers on the diagnostic table.

2: Lack of communication may be due to a partial malfunction of the class 2 serial data circuit or due to a total malfunction of the class 2 serial data circuit. The specified procedure will determine the particular condition.

5: Tests for an open in the Passlock(tm) sensor signal circuit, which may not set a DTC (B2958) under certain conditions.

6: The presence of DTCs which begin with "U" indicate some other module is not communicating. The specified procedure will compile all the available information before tests are performed.

7: The presence of DTC P0601, P0602, or P0604 indicates an internal fault in the PCM.

8: The presence of DTC B1000 indicates an internal module fault.

9: The presence of DTC P0562, P0563, or P0621 indicates a low or high voltage condition.

Diagnostic System Check - Theft Deterrent

Step	Action	Yes	No
Schematic Reference: Theft Deterrent System Schematics			
1	Install a scan tool. Does the scan tool power up?	Go to Step 2	Go to Scan Tool Does Not Power Up in Data Link Communications
2	<ol style="list-style-type: none"> 1. Turn ON the ignition, with the engine OFF. 2. Attempt to establish communication with the following control modules: <ul style="list-style-type: none"> • The powertrain control module (PCM) • The body control module (BCM) • The instrument panel cluster (IPC) Does the scan tool communicate with		Go to Scan Tool Does Not Communicate with Class 2 Device in Data Link

	the all the listed control modules?	Go to Step 3	Communications
3	<p>IMPORTANT: The engine may start during the following step.</p> <ol style="list-style-type: none"> 1. Turn OFF the engine as soon as you have observed the crank power mode. 2. Access the Class 2 Power Mode parameter in the Diagnostic Circuit Check menu on the scan tool. <p>IMPORTANT: Insure that all ignition switch positions are observed, including the OFF position.</p> <ol style="list-style-type: none"> 3. Rotate the ignition switch through all positions while observing the Class 2 Power Mode parameter. <p>Does the Class 2 Power Mode parameter reading match the ignition switch position for all switch positions?</p>	<p>Go to Step 4</p>	<p>Go to Diagnostic Starting Point - Body Control System in Body Control System</p>
4	<p>Select the display DTCs function on the scan tool for the following control modules:</p> <ul style="list-style-type: none"> • The PCM • The BCM • The IPC <p>Does the scan tool display any DTCs?</p>	<p>Go to Step 6</p>	<p>Go to Step 5</p>
5	<ol style="list-style-type: none"> 1. Momentarily rotate the ignition switch to CRANK. Do not start the vehicle. 2. Release the ignition switch to ON. 3. With a scan tool, observe the 		

	Passlock Code in the Body Control Module Security Data list.		Go to Symptoms - Theft Deterrent
	Does the scan tool display OPEN?	Go to DTC B2958	
6	Does the scan tool display any DTCs which begin with a "U"?	Go to Scan Tool Does Not Communicate with Class 2 Device in Data Link Communications	Go to Step 7
7	Does the scan tool display DTC P0601, P0602 or P0604?	Go to Diagnostic Trouble Code (DTC) List in Engine Controls - 2.2L (L61) or Diagnostic Trouble Code (DTC) List in Engine Controls - 3.5L (L66)	Go to Step 8
8	Does the scan tool display DTC B1000?	Go to DTC B1000 in Body Control System	Go to Step 8
9	Does the scan tool display DTC P0562, P0563, P0621, or P0622?	Go to Diagnostic Trouble Code (DTC) List in Engine Electrical	Go to Diagnostic Trouble Code (DTC) List

SCAN TOOL OUTPUT CONTROLS

Scan Tool Output Controls

Scan Tool Output Control	Additional Menu Selection(s)	Description
Daytime Running Lamps	Light Test	The BCM actuates the DRL relay when you select ON. The headlamps should illuminate until commanded OFF.
Horn Relay	Miscellaneous Test	The BCM actuates the horn relay for 5 seconds when you select ON. The horn should sound for 5 seconds.
Passlock Power	Output Control	The BCM turns the Passlock power control ON or OFF as commanded by the scan tool.
Security Lamp	Miscellaneous Test	The BCM actuates the security LED when you select ON. The security LED should illuminate until commanded OFF.

SCAN TOOL DATA LIST

Body Control Module (BCM) Scan Tool Data List

Scan Tool Parameter	Data List	Units Displayed	Typical Data Value
Ignition ON/Engine OFF/Vehicle in PARK/Headlamps in AUTO			
Auto Learn Timer	Security Data	Seconds	0-600
Battery Voltage	Security Data	Volts	Varies

Content Theft Lamp	Security Data	ON/OFF	OFF
Content Theft State	Security Data	ON/OFF	OFF
Door Handle Switch	Input 1	ACTIVE/INACTIVE	ACTIVE (door open)
Door Key Switch	Security Data	ACTIVE/INACTIVE	ACTIVE
Driver Door Jamb Switch	Input 1	ACTIVE/INACTIVE	ACTIVE (door open)
Ignition 1	Security Data	ACTIVE/INACTIVE	ACTIVE
Ignition 3	Security Data	ACTIVE/INACTIVE	ACTIVE
Manufacture Enable Counter	Module Information 1	0-255	0
Module Part Number	Module Information 1	Numeric	Varies
Passlock Code	Security Data	Open/Short/Tamper/Numeric	Valid Code 1-10
Passlock Data Voltage	Security Data	Volts	0.86-5 Volts
Passlock State	Security Data	Ignition Off/Tamper/Fail Enable/Fail Enable Dec/Seedkey Lrn Pend/Seedkey Learn/Auto Learn Pend/Learn Passlock/Monitor Passlock/Normal Decision/Auto Learn	Monitor Passlock
Security Calibration Number	Module Information 2	Numeric	Varies
Security Lamp State	Security Data	ON/OFF/FLASHING	OFF
Security Suffix	Module Information 2	Two Letters	Varies
Tamper Timer	Security Data	Seconds	0-600
VCM/PCM Fail Enable	Security Data	YES/NO	NO
VCM/PCM Fuel Continue	Security Data	YES/NO	YES
VCM/PCM Learn Timer	Security Data	ACTIVE/INACTIVE	INACTIVE
VTD Fuel Disable	Security Data	ACTIVE/INACTIVE	INACTIVE
VTD Fuel Disable Until Ignition Off	Security Data	YES/NO	NO
VTD Password Learn Mode	Security Data	ACTIVE/INACTIVE	INACTIVE

Powertrain Control Module (PCM) Scan Tool Data List

Scan Tool Parameter	Data List	Units Displayed	Typical Data Value
Ignition ON/Engine OFF/Vehicle in PARK/Headlamps in AUTO			
PCM/VCM in VTD Fail Enable	Engine Data 1	Yes/No	No
VTD Auto Learn Timer	Engine Data 1	Active/Inactive	Inactive
VTD Fuel Disable	Engine Data 1	Active/Inactive	Inactive
VTD Fuel Disable Until Ign. OFF	Engine Data 1	Yes/No	No

SCAN TOOL DATA DEFINITIONS

Auto Learn Timer

The scan tool displays the seconds used by the BCM to learn valid code from the Passlock(tm) sensor. The learn procedure consists of 3 consecutive periods.

Battery Voltage

The scan tool displays the battery system voltage.

Content Theft Lamp

The scan tool displays the state of the SECURITY lamp. The scan tool displays ON when activated by an unauthorized entry.

Content Theft State

The scan tool displays the state of the content theft feature. The scan tool displays ON when activated by an unauthorized entry.

Door Handle Switch

The scan tool displays the position of the door handle. The scan tool displays ACTIVE when a door handle is raised and INACTIVE with all doors closed and the door handles at rest.

Door Key Switch

The scan tool displays the state of the door key switch. The scan tool displays ACTIVE when the switch is activated in either door key cylinder.

Drivers Door Jamb Switch

The scan tool displays the position of the drivers door. The scan tool displays ACTIVE when the drivers door is open.

Ignition 1

The scan tool displays the state of the ignition switch. The scan tool displays ACTIVE when the ignition switch is in the RUN or CRANK position.

Ignition 3

The scan tool displays the state of the ignition switch. The scan tool displays ACTIVE when the ignition switch is in the RUN position.

Manufacture Enable Counter (MEC)

The scan tool displays the actual value for the MEC in the BCM. This information is for the assembly plant only.

Module Part Number

The scan tool displays the part number assigned to the BCM that is currently in the vehicle.

Passlock(tm) Code

The scan tool displays the validity of the Passlock(tm) code received by the BCM. The scan tool displays OPEN, SHORTED, TAMPER and a valid code as a numeric value (1-10).

Passlock(tm) Data Voltage

The scan tool displays the voltage code from the Passlock sensor to the Body Control Module (BCM). A valid Passlock sensor voltage of 5 volts will be displayed on the scan tool when the ignition cylinder is turned to the on position. Once the ignition cylinder has been rotated to the crank position the Passlock voltage will drop from 5 to 0.86-4.28 volts depending on which of the 10 possible Passlock sensors the vehicle is equipped with. The (BCM) then determines if the voltage received is a valid or invalid code. The scan tool will continue to display the Passlock voltage code (0.86-4.28 volts) received by the (BCM) when the ignition cylinder returns to the on/run position.

Passlock(tm) State

The scan tool displays the state of the Passlock(tm) system.

Security Calibration Number

The scan tool displays the security calibration part number in the BCM.

Security Lamp State

The scan tool displays the state of the SECURITY lamp. The scan tool displays ON, OFF or FLASHING.

Security Suffix

The scan tool displays the security identification number in the BCM

Tamper Timer

The scan tool displays the time remaining when in the tamper mode. The timer starts when the ignition switch is turned to the RUN position and the BCM receives a Passlock(tm) data voltage different from the last learned voltage. The timer has a delay of 10 minutes and will stay active even if the ignition switch is cycled from the RUN to the OFF position.

VCM/PCM Fail Enable

The scan tool displays the state of the VCM/PCM fail enable mode. The scan tool displays YES when the Passlock(tm) system transitions from the Monitor Passlock(tm) Data state to the VCM/PCM Fail Enable state.

VCM/PCM Fuel Continue

The scan tool displays the state of the VCM/PCM fuel continue mode. The scan tool displays YES when the Passlock(tm) system verifies a valid password to the BCM.

VCM/PCM Learn Timer

The scan tool displays the state of the VCM/PCM learn timer. The scan tool displays INACTIVE when the BCM is not in a learn mode.

VTD Fuel Disable

The scan tool displays the state of the VTD fuel disable mode. The scan tool displays INACTIVE when the Passlock(tm) system verifies a valid password.

VTD Fuel Disable Until Ignition Off

The scan tool displays the state of the VTD fuel disable until Ignition off mode. The scan tool displays NO when the Passlock(tm) system verifies a valid password.

VTD Password Learn Mode

The scan tool displays the state of the VTD password learn mode. The scan tool displays INACTIVE when the Passlock(tm) system is not in a learn mode.

DIAGNOSTIC TROUBLE CODE (DTC) LIST

Diagnostic Trouble Code (DTC) List

DTC	Diagnostic Procedure	Module
IMPORTANT:		
Before you use this table, diagnose P0601, P0602, and P0604. Refer to <u>Diagnostic System Check -</u>		

Theft Deterrent . Diagnose all Bxxxx codes prior to diagnosing any remaining Pxxxx code.

B0688	<u>DTC B0688</u>	BCM
B0689	<u>DTC B0689</u>	BCM
B2947	<u>DTC B2947</u>	BCM
B2948	<u>DTC B2948</u>	BCM
B2957	<u>DTC B2957</u>	BCM
B2958	<u>DTC B2958</u>	BCM
B2960	<u>DTC B2960</u>	BCM
B3031	<u>DTC B3031</u>	BCM
B3033	<u>DTC B3033</u>	BCM
P1629	<u>DTC P1629</u>	PCM
P1631	<u>DTC P1631</u>	PCM

PXXXX Other PCM DTCs

Refer to **Diagnostic System Check - Engine Controls** in Engine Controls - 2.2L (L61).

Refer to **Diagnostic System Check - Engine Controls** in Engine Controls - 3.5L (L66).

DTC B0688**Circuit Description**

The security indicator is used by both the VTD system and the CTD system. The security indicator is controlled by the body control module (BCM) via the security indicator control circuit. When VTD or CTD requests the security indicator be illuminated, the BCM grounds the security indicator control circuit, illuminating the security indicator.

Conditions for Setting the DTC

The BCM detects a short to battery in the security indicator control circuit.

Action Taken When the DTC Sets

The BCM will set and store DTC B0688

Conditions for Clearing the MIL/DTC

- The BCM no longer detects a short to battery in the security indicator control circuit.
- A scan tool is used to clear the DTC.

DTC B0688

Step	Action	Yes	No
Schematic Reference: Theft Deterrent System Schematics			
Connector End View Reference: Theft Deterrent System Connector End Views			
1	Did you perform the Diagnostic System Check- Theft Deterrent?		Go to Diagnostic System Check -

		Go to Step 2	<u>Theft Deterrent</u>
2	<p>1. Turn ON the ignition with the engine OFF.</p> <p>2. With the scan tool, command the security indicator ON and OFF.</p> <p>Does the security indicator turn ON and OFF with each command?</p>	<p>Go to Testing for Intermittent Conditions and Poor Connections in Wiring Systems</p>	Go to Step 3
3	<p>Test for a short to battery in the security indicator control circuit. Refer to Circuit Testing and Wiring Repairs in Wiring Systems.</p> <p>Did you find and correct the condition?</p>	Go to Step 6	Go to Step 4
4	<p>Inspect for poor connections at the harness connector of the BCM. Refer to Testing for Intermittent Conditions and Poor Connections and Connector Repairs in Wiring Systems.</p> <p>Did you find and correct the condition?</p>	Go to Step 6	Go to Step 5
5	<p>IMPORTANT:</p> <p>The BCM programming and setup procedure must be performed when replacing the BCM. Refer to Body Control Module (BCM) Programming/RPO Configuration in Body Control System.</p> <p>Replace the BCM. Refer to Body Control Module Replacement in Body Control System. Did you complete the replacement?</p>	Go to Step 6	-
6	<p>Operate the system in order to verify the repair.</p> <p>Did you correct the condition?</p>	System OK	Go to Step 1

DTC B0689

Circuit Description

The security indicator is used by both the VTD system and the CTD system. The security indicator is controlled by the body control module (BCM) via the security indicator control circuit. When VTD or CTD requests the security indicator be illuminated, the BCM grounds the security indicator control circuit, illuminating the security indicator.

Conditions for Setting the DTC

The BCM detects an open in the security indicator control circuit when the security indicator is commanded On.

Action Taken When the DTC Sets

The BCM will set and store DTC B0689

Conditions for Clearing the MIL/DTC

- The BCM no longer detects an open in the security indicator control circuit.
- A scan tool is used to clear the DTC.

DTC B0689

Step	Action	Yes	No
Schematic Reference: Theft Deterrent System Schematics			
Connector End View Reference: Theft Deterrent System Connector End Views			
1	Did you perform the Diagnostic System Check-Theft Deterrent?	Go to Step 2	Go to <u>Diagnostic System Check - Theft Deterrent</u>
2	<ol style="list-style-type: none"> 1. Turn ON the ignition with the engine OFF. 2. With the scan tool, command the security indicator ON and OFF. Does the security indicator turn ON and OFF with each command?	Go to <u>Testing for Intermittent Conditions and Poor Connections</u> in Wiring Systems	Go to Step 3
3	<ol style="list-style-type: none"> 1. Disconnect the body control module (BCM) connector containing the security indicator control circuit. 2. Using a fused jumper wire and the appropriate terminal adapter, ground the security indicator control circuit. Does the security indicator illuminate?	Go to Step 6	Go to Step 4
4	Test for an open or short to ground in the security indicator control circuit. Refer to <u>Circuit Testing</u> and <u>Wiring Repairs</u> in Wiring Systems. Did you find and correct the condition?	Go to Step 9	Go to Step 5
5	Inspect for poor connections at the harness connector of the instrument panel cluster (IPC). Refer to <u>Testing for Intermittent Conditions and Poor Connections</u> and <u>Connector Repairs</u> in Wiring Systems. Did you find and correct the condition?	Go to Step 9	Go to Step 7
6	Inspect for poor connections at the harness connector of the BCM. Refer to <u>Testing for Intermittent Conditions and Poor Connections</u> and <u>Connector Repairs</u> in Wiring Systems. Did you find and correct the condition?	Go to Step 9	Go to Step 8
7	Replace the IPC. Refer to <u>Instrument Panel Cluster (IPC) Replacement</u> in Instrument Panel, Gages, and Console.		

	Did you complete the replacement?	Go to Step 9	-
8	<p>IMPORTANT: The BCM programming and setup procedure must be performed when replacing the BCM. Refer to <u>Body Control Module (BCM) Programming/RPO Configuration in Body Control System.</u></p> <p>Replace the BCM. Refer to <u>Body Control Module Replacement</u> in Body Control System. Did you complete the replacement?</p>	Go to Step 9	-
9	Operate the system in order to verify the repair. Did you correct the condition?	System OK	Go to Step 1

DTC B2947

Circuit Description

The Passlock(tm) system is provided in order to prevent vehicle theft if the ignition lock cylinder is forced to rotate or the ignition switch is operated while separated from the ignition lock cylinder case. The body control module (BCM) provides security system sensor power and low reference for the Passlock(tm) sensor. The BCM also measures the security system sensor voltage.

When the correct key is used to start the vehicle, a magnet on the lock cylinder passes close to the Passlock(tm) sensor within the ignition lock cylinder case. The magnet activates the security hall effect sensor in the Passlock (tm) sensor which completes a circuit from the security sensor signal circuit through a resistor to the security sensor low reference circuit. The resistance value will vary from vehicle to vehicle. The BCM will measure the voltage on the security sensor signal circuit and compare this voltage to a previously learned voltage. If the voltage measured is within the valid range, the BCM will send a class 2 message to the powertrain control module (PCM) to enable vehicle starting. If the voltage measured is not within the valid range, a class 2 message will be sent to the PCM to disable starting of the vehicle.

Conditions for Setting the DTC

The BCM detects a short to ground on the Passlock sensor power circuit for one second, with the ignition switch in the ACCESSORY, ON, or START position.

Action Taken When the DTC Sets

- The BCM stores DTC B2947 in memory.
- The BCM sends a message to the instrument cluster to turn the SECURITY indicator ON.
- In addition, the BCM will take 1 of 2 actions:
 - If the Passlock sensor power circuit is shorted to ground when attempting to start the engine, the BCM will NOT send a message to the PCM to enable fuel delivery to the engine. The vehicle will exhibit an engine no start or starts then stalls condition.
 - If the Passlock sensor power circuit is shorted to ground after the engine has started, the BCM enters a fail-enable mode. Upon subsequent engine start attempts, the BCM will send a password

message to the PCM via the class 2 serial data link to enable fuel delivery to the engine. The engine will start.

Conditions for Clearing the DTC

- The BCM no longer detects a short to ground in the Passlock sensor power circuit.
- When a short to ground is no longer present on the Passlock sensor power circuit, the ignition switch must be cycled from OFF to ON before this DTC can change from a current DTC to a history DTC.
- A history DTC will clear after 100 consecutive ignition cycles if the condition for the malfunction is no longer present.

Diagnostic Aids

Inspect for a short between the Passlock sensor power circuit and the Passlock sensor ground circuit, or a short to ground on the Passlock sensor power circuit.

Test Description

The numbers below refer to the step numbers on the diagnostic table.

2: Verifies that DTC B2947 is a current DTC.

3: Tests for a short to ground in the Passlock(tm) sensor or the pigtail harness.

DTC B2947

Step	Action	Yes	No
Schematic Reference: Theft Deterrent System Schematics			
Connector End View Reference: Theft Deterrent System Connector End Views			
1	Did you perform the Theft Deterrent Diagnostic System Check?	Go to Step 2	Go to Diagnostic System Check - Theft Deterrent
2	1. Install a scan tool. 2. Turn ON the ignition, with the engine OFF. 3. Select the body control module display DTCs function on the scan tool. Does the scan tool display DTC B2947 as a current DTC?	Go to Step 3	Go to Testing for Intermittent Conditions and Poor Connections in Wiring Systems
3	1. Disconnect the Passlock(tm) sensor connector. 2. Measure the voltage between the Passlock(tm) battery voltage circuit and a good ground. Does the voltage measure approximately battery voltage?	Go to Step 6	Go to Step 4
4	Test the Passlock(tm) battery voltage circuit for a short to ground. Refer to Circuit Testing and Wiring Repairs in Wiring Systems. Did you find and correct the condition?	Go to Step 10	Go to Step 5

5	Inspect for poor connections at the body control module (BCM). Refer to Testing for Intermittent Conditions and Poor Connections and Connector Repairs in Wiring Systems. Did you find and correct the condition?	Go to Step 10	Go to Step 7
6	Inspect for poor connections at the Passlock(tm) sensor. Refer to Testing for Intermittent Conditions and Poor Connections and Connector Repairs in Wiring Systems. Did you find and correct the condition?	Go to Step 10	Go to Step 8
7	IMPORTANT: When replacing the BCM refer to <u>Body Control Module (BCM) Programming/RPO Configuration in Body Control System.</u> Replace the BCM. Refer to Body Control Module Replacement in Body Control System. Did you complete the replacement?	Go to Step 10	-
8	Replace the Passlock(tm) sensor. Refer to Ignition Lock Cylinder Replacement in Steering Wheel and Column. Did you complete the replacement?	Go to Step 9	-
9	Perform the Passlock(tm) learn procedure. Refer to Programming Theft Deterrent System Components . Did you complete the procedure?	Go to Step 10	-
10	1. Use the scan tool in order to clear the DTCs. 2. Operate the vehicle within the conditions for running the DTC as specified in the supporting text. Does the DTC reset?	Go to Step 3	System OK

DTC B2948

Circuit Description

The Passlock(tm) system is provided in order to prevent vehicle theft if the ignition lock cylinder is forced to rotate or the ignition switch is operated while separated from the ignition lock cylinder case. The body control module (BCM) provides security system sensor power and low reference for the Passlock(tm) sensor. The BCM also measures the security system sensor voltage.

When the correct key is used to start the vehicle, a magnet on the lock cylinder passes close to the Passlock(tm) sensor within the ignition lock cylinder case. The magnet activates the security hall effect sensor in the Passlock (tm) sensor which completes a circuit from the security sensor signal circuit through a resistor to the security sensor low reference circuit. The resistance value will vary from vehicle to vehicle. The BCM will measure the voltage on the security sensor signal circuit and compare this voltage to a previously learned voltage. If the voltage measured is within the valid range, the BCM will send a class 2 message to the powertrain control module (PCM) to enable vehicle starting. If the voltage measured is not within the valid range, a class 2 message will be sent to the PCM to disable starting of the vehicle.

Conditions for Running the DTC

The ignition switch is cycled to CRANK, released to ON and then cycled to OFF.

Conditions for Setting the DTC

- The BCM turns the Passlock(tm) sensor power OFF after the ignition switch is turned OFF.
- If the BCM still senses battery voltage for 1 second after the shut down of voltage, this DTC will set.

Action Taken When the DTC Sets

- The BCM stores DTC B2948 in memory.
- The vehicle will start and run.
- The SECURITY indicator remains illuminated.

Conditions for Clearing the DTC

- The BCM no longer detects a short to battery in the Passlock sensor power circuit.
- When a short to battery is no longer present on the Passlock sensor power circuit, the ignition switch must be cycled from OFF to ON before this DTC can change from a current DTC to a history DTC.
- A history DTC will clear after 100 consecutive ignition cycles if the condition for the malfunction is no longer present.

Diagnostic Aids

Inspect for a short battery on the Passlock sensor power circuit with the ignition switch OFF.

Test Description

The number below refers to the step number on the diagnostic table.

3: Tests for a short to battery positive on the Passlock battery voltage circuit.

DTC B2948

Step	Action	Yes	No
Schematic Reference: Theft Deterrent System Schematics Connector End View Reference: Theft Deterrent System Connector End Views			
1	Did you perform the Theft Deterrent Diagnostic System Check?	Go to Step 2	Go to Diagnostic System Check - Theft Deterrent
2	1. Install a scan tool. 2. Turn ON the ignition, with the engine OFF. 3. Select the body control module display DTCs function on the scan tool.		Go to Testing for Intermittent

	Does the scan tool display DTC B2948 as a current DTC?	Go to Step 3	Conditions and Poor Connections in Wiring Systems
3	<p>IMPORTANT: The use of a DMM is crucial in this step because voltage may be measured for 10 milliseconds.</p> <ol style="list-style-type: none"> 1. Disconnect the Passlock(tm) sensor connector. 2. Connect a DMM between the Passlock(tm) battery voltage circuit and a good ground. 3. Set the "MIN MAX" mode to the 1 millisecond peak and start to record. 4. Turn OFF the ignition. 5. Stop recording and review the recorded "MIN" value. <p>Does the voltage measure near zero volts?</p>	Go to Step 7	Go to Step 4
4	<p>Test the Passlock battery voltage circuit for a short to voltage. Refer to Circuit Testing and Wiring Repairs in Wiring Systems. Did you find and correct the condition?</p>	Go to Step 10	Go to Step 5
5	<p>Inspect for poor connections at the BCM. Refer to Testing for Intermittent Conditions and Poor Connections and Connector Repairs in Wiring Systems. Did you find and correct the condition?</p>	Go to Step 10	Go to Step 6
6	<p>Inspect for poor connections at the Passlock(tm) sensor. Refer to Testing for Intermittent Conditions and Poor Connections in Wiring Systems. Did you find and correct the condition?</p>	Go to Step 10	Go to Step 8
7	<p>IMPORTANT: When replacing the BCM, refer to Body Control Module (BCM) Programming/RPO Configuration in Body Control System.</p> <p>Replace the body control module. Refer to Body Control Module Replacement in Body Control System. Did you complete the replacement?</p>	Go to Step 10	-
8	<p>Replace the Passlock(tm) sensor. Refer to Ignition Lock Cylinder Replacement in Steering Wheel and Column. Did you complete the replacement?</p>	Go to Step 9	-
9	<p>Perform the Passlock(tm) learn procedure. Refer to Programming Theft Deterrent System Components. Did you complete the repair?</p>	Go to Step 10	-
	<ol style="list-style-type: none"> 1. Use the scan tool in order to clear the DTCs. 		

10	2. Operate the vehicle within the conditions for running the DTC as specified in the supporting text.	Go to Step 3	System OK
Does the DTC reset?			

DTC B2957

Circuit Description

The Passlock(tm) system is provided in order to prevent vehicle theft if the ignition lock cylinder is forced to rotate or the ignition switch is operated while separated from the ignition lock cylinder case. The body control module (BCM) provides security system sensor power and low reference for the Passlock(tm) sensor. The BCM also measures the security system sensor voltage.

When the correct key is used to start the vehicle, a magnet on the lock cylinder passes close to the Passlock(tm) sensor within the ignition lock cylinder case. The magnet activates the security hall effect sensor in the Passlock (tm) sensor which completes a circuit from the security sensor signal circuit through a resistor to the security sensor low reference circuit. The resistance value will vary from vehicle to vehicle. The BCM will measure the voltage on the security sensor signal circuit and compare this voltage to a previously learned voltage. If the voltage measured is within the valid range, the BCM will send a class 2 message to the powertrain control module (PCM) to enable vehicle starting. If the voltage measured is not within the valid range, a class 2 message will be sent to the PCM to disable starting of the vehicle.

Conditions for Setting the DTC

- The ignition switch is ON.
- The BCM signal input is less than 0.4 volts for 1 second after turning the ignition switch to the CRANK position.

Action Taken When the DTC Sets

- The vehicle will not start if the fault occurs before you start the vehicle. The security indicator will flash for 10 minutes then turn ON steady.
- If the vehicle is running when the fault occurs, the BCM will be in the fail enable mode allowing the vehicle to start and run. The security indicator will be ON.

Conditions for Clearing the DTC

- The DTC will clear once the ignition cycle has occurred without the fault recurring.
- The BCM history codes will clear once 100 concurrent ignition cycles occur without the fault recurring.
- Using a scan tool.

Diagnostic Aids

- Use a scan tool in order to inspect the Passlock(tm) data voltage and the Passlock(tm) code.

- Inspect the Passlock(tm) sensor harness for an intermittent or a short to ground. Refer to **Testing for Intermittent Conditions and Poor Connections** in Wiring Systems.
- Following a repair the tamper timer needs 10 minutes in order to expire.

Test Description

The numbers below refer to the step numbers on the diagnostic table.

3: Tests for proper operation of the circuit in the high voltage range.

4: Tests for a short to ground in the Passlock(tm) sensor signal circuit.

DTC B2957

Step	Action	Value (s)	Yes	No
Schematic Reference: <u>Theft Deterrent System Schematics</u>				
Connector End View Reference: <u>Theft Deterrent System Connector End Views</u>				
1	Did you perform the Theft Deterrent (VTD) Diagnostic System Check?	-	Go to Step 2	Go to Diagnostic System Check - Theft Deterrent
2	<ol style="list-style-type: none"> 1. Install a scan tool. 2. Momentarily rotate the ignition switch to CRANK. Do not start the vehicle. 3. Release the ignition switch to ON. 4. With a scan tool, observe the Passlock data voltage in the Body Control Module Security Data list. <p>Does the scan tool indicate that the Passlock (tm) data voltage is within the specified range?</p>	0.4-4.9 V	Go to Testing for Intermittent Conditions and Poor Connections in Wiring Systems	Go to Step 3
3	<ol style="list-style-type: none"> 1. Turn OFF the ignition. 2. Disconnect the Passlock (tm) sensor connector. 3. Turn ON the ignition, with the engine OFF. 4. With a scan tool, observe the Passlock (tm) data voltage in the Body Control Module Security Data list. <p>Does the scan tool indicate that the Passlock (tm) data voltage is greater than the specified value?</p>	4.9 V	Go to Step 7	Go to Step 4
	Test the Passlock(tm) sensor signal circuit for			

4	a short to ground. Refer to Circuit Testing and Wiring Repairs in Wiring Systems. Did you find and correct the condition?	-	Go to Step 10	Go to Step 5
5	Inspect for poor connections at the BCM. Refer to Testing for Intermittent Conditions and Poor Connections and Connector Repairs in Wiring Systems. Did you find and correct the condition?	-	Go to Step 10	Go to Step 6
6	IMPORTANT: When replacing the BCM, refer to Body Control Module (BCM) Programming/RPO Configuration in Body Control System. Replace the body control module. Refer to Body Control Module Replacement in Body Control System. Did you complete the replacement?	-	Go to Step 10	-
7	Inspect for poor connections at the Passlock (tm) sensor. Refer to Testing for Intermittent Conditions and Poor Connections and Connector Repairs in Wiring Systems. Did you find and correct the condition?	-	Go to Step 10	Go to Step 8
8	Replace the Passlock(tm) sensor in the electronic column lock module assembly. Refer to Ignition Lock Cylinder Replacement in Steering Wheel and Column. Did you complete the replacement?	-	Go to Step 9	-
9	Perform the Programming Theft Deterrent System Components procedure. Is the repair complete?	-	Go to Step 10	-
10	<ol style="list-style-type: none"> 1. Use the scan tool in order to clear the DTCs. 2. Turn OFF the ignition. 3. Turn ON the ignition, with the engine OFF. 4. Select the body control module display DTCs function on the scan tool. Does the DTC reset?	-	Go to Step 3	System OK

DTC B2958

Circuit Description

The Passlock(tm) system is provided in order to prevent vehicle theft if the ignition lock cylinder is forced to rotate or the ignition switch is operated while separated from the ignition lock cylinder case. The body control module (BCM) provides security system sensor power and low reference for the Passlock(tm) sensor. The BCM also measures the security system sensor voltage.

When the correct key is used to start the vehicle, a magnet on the lock cylinder passes close to the Passlock(tm) sensor within the ignition lock cylinder case. The magnet activates the security hall effect sensor in the Passlock (tm) sensor which completes a circuit from the security sensor signal circuit through a resistor to the security sensor low reference circuit. The resistance value will vary from vehicle to vehicle. The BCM will measure the voltage on the security sensor signal circuit and compare this voltage to a previously learned voltage. If the voltage measured is within the valid range, the BCM will send a class 2 message to the powertrain control module (PCM) to enable vehicle starting. If the voltage measured is not within the valid range, a class 2 message will be sent to the PCM to disable starting of the vehicle.

Conditions for Setting the DTC

- The ignition switch is ON.
- The BCM signal input is greater than 4.9 volts for 1 second after turning the ignition switch to the CRANK position.

Action Taken When the DTC Sets

- The DTC will set only when the engine is running
- The BCM will be in the fail enable mode allowing the vehicle to start and run.
- The security indicator will be ON.

Conditions for Clearing the DTC

- The current DTC will clear once an ignition cycle has occurred without the fault recurring.
- After 100 concurrent ignition cycles occur without the fault recurring, a history DTC clears.
- Using a scan tool.

Diagnostic Aids

- Use a scan tool in order to inspect the Passlock(tm) data voltage and the Passlock(tm) code.
- Inspect the Passlock(tm) sensor harness for an intermittent or a short to battery. Refer to **Testing for Intermittent Conditions and Poor Connections** in Wiring Systems.
- You may be directed to this table from the VTD Diagnostic System Check without a DTC B2958 being set. If you were directed to this table, follow all of the steps in this diagnostic table.
- When directed to this table, DTC B2958 may have a history status.

Test Description

The numbers below refer to the step numbers on the diagnostic table.

3: Tests for proper operation of the circuit in the high voltage range.

4: Tests for proper operation of the circuit in the low voltage range.

5: Tests for high resistance or an open in the 12V reference circuit.

7: Tests for a short to voltage, a high resistance, or an open in the signal circuit.

8: Tests for high resistance or an open in the ground circuit.

DTC B2958

Step	Action	Value (s)	Yes	No
Schematic Reference: Theft Deterrent System Schematics				
Connector End Reference: Theft Deterrent System Connector End Views				
1	Did you perform the Vehicle Theft Deterrent (VTD) Diagnostic System Check?	-	Go to Step 2	Go to Diagnostic System Check - Theft Deterrent
2	<ol style="list-style-type: none"> 1. Install a scan tool. 2. Momentarily rotate the ignition switch to CRANK, do not start the vehicle. 3. Release the ignition switch to ON. 4. With a scan tool, observe the Passlock (tm) Data Voltage in the Body Control Module Security Data list. <p>Does the scan tool indicate that the Passlock Data Voltage is within the specified range?</p>	0.4-4.9 V	Go to Testing for Intermittent Conditions and Poor Connections in Wiring Systems	Go to Step 3
3	<ol style="list-style-type: none"> 1. Turn OFF the ignition. 2. Disconnect the Passlock(tm) sensor. 3. Turn ON the ignition, with the engine OFF. 4. With a scan tool observe the Passlock (tm) Data Voltage in the Body Control Module Security Data list. <p>Does the scan tool indicate that the Passlock (tm) Data Voltage is greater than the specified value?</p>	4.9 V	Go to Step 4	Go to Step 9
4	<ol style="list-style-type: none"> 1. Turn OFF the ignition. 2. Connect a 3 amp fused jumper wire between the signal circuit of the Passlock(tm) sensor and the ground circuit of the Passlock(tm) sensor. 3. Turn ON the ignition, with the engine OFF. 	0.4 V		

	<p>4. With a scan tool observe the Passlock (tm) Data Voltage in the Body Control Module Security Data list.</p> <p>Does the scan tool indicate that the Passlock (tm) Data Voltage is less than the specified value?</p>		Go to Step 5	Go to Step 7
5	<p>1. Disconnect the fused jumper wire.</p> <p>2. Measure the voltage between the 12V reference circuit of the Passlock(tm) sensor and the ground circuit of the Passlock(tm) sensor.</p> <p>Does the voltage measure less than the specified value?</p>	12.0 V	Go to Step 6	Go to Step 11
6	<p>Test the 12V reference circuit of the Passlock (tm) sensor for a high resistance or an open. Refer to Circuit Testing and Wiring Repairs in Wiring Systems.</p> <p>Did you find and correct the condition?</p>	-	Go to Step 14	Go to Step 9
7	<p>Test the signal circuit of the Passlock(tm) sensor for a short to voltage, a high resistance, or an open. Refer to Circuit Testing and Wiring Repairs in Wiring Systems.</p> <p>Did you find and correct the condition?</p>	-	Go to Step 14	Go to Step 8
8	<p>Test the ground circuit of the Passlock(tm) sensor for a high resistance or an open. Refer to Circuit Testing and Wiring Repairs in Wiring Systems.</p> <p>Did you find and correct the condition?</p>	-	Go to Step 14	Go to Step 9
9	<p>Inspect for poor connections at the BCM. Refer to Testing for Intermittent Conditions and Poor Connections and Connector Repairs in Wiring Systems.</p> <p>Did you find and correct the condition?</p>	-	Go to Step 14	Go to Step 10
10	<p>IMPORTANT:</p> <p>When replacing the BCM, refer to <u>Body Control Module (BCM) Programming/RPO Configuration in Body Control System.</u></p> <p>Replace the body control module. Refer to Body Control Module Replacement in Body Control System. Did you complete the replacement?</p>	-	Go to Step 14	-
	Inspect for poor connections at the Passlock			

11	(tm) sensor. Refer to Testing for Intermittent Conditions and Poor Connections and Connector Repairs in Wiring Systems. Did you find and correct the condition?	-	Go to Step 14	Go to Step 12
12	Replace the Passlock(tm) sensor in the electronic column lock module assembly. Refer to Ignition Lock Cylinder Replacement in Steering Wheel and Column. Did you complete the replacement?	-	Go to Step 13	-
13	Perform the Programming Theft Deterrent System Components procedure. Is the repair complete?	-	Go to Step 14	-
14	<ol style="list-style-type: none"> 1. Use the scan tool in order to clear the DTCs. 2. Turn OFF the ignition. 3. Momentarily rotate the ignition switch to CRANK. Do not start the vehicle. 4. Release the ignition switch to ON. 5. Select the body control module display DTCs function on the scan tool. Does the DTC reset?	-	Go to Step 3	Go to Step 15
15	Attempt to start the vehicle. Does the engine start and run?	-	System OK	Go to Step 3

DTC B2960

Circuit Description

The Passlock(tm) system is provided in order to prevent vehicle theft if the ignition lock cylinder is forced to rotate or the ignition switch is operated while separated from the ignition lock cylinder case. The body control module (BCM) provides security system sensor power and low reference for the Passlock(tm) sensor. The BCM also measures the security system sensor voltage.

When the correct key is used to start the vehicle, a magnet on the lock cylinder passes close to the Passlock(tm) sensor within the ignition lock cylinder case. The magnet activates the security hall effect sensor in the Passlock (tm) sensor which completes a circuit from the security sensor signal circuit through a resistor to the security sensor low reference circuit. The resistance value will vary from vehicle to vehicle. The BCM will measure the voltage on the security sensor signal circuit and compare this voltage to a previously learned voltage. If the voltage measured is within the valid range, the BCM will send a class 2 message to the powertrain control module (PCM) to enable vehicle starting. If the voltage measured is not within the valid range, a class 2 message will be sent to the PCM to disable starting of the vehicle.

Conditions for Setting the DTC

- The BCM will inspect for a valid code when the ignition is rotated from ON to CRANK and will continue to monitor the signal during the engine running period.
- The BCM is reading a valid but different code value than previously learned from the Passlock(tm) sensor.

Action Taken When the DTC Sets

- The vehicle will not start if the fault occurs before you start the vehicle. The security indicator will be FLASHING.
- If the vehicle is running when the fault occurs, the BCM will be in the fail enable mode allowing the vehicle to start and run. The security indicator will be ON.

Conditions for Clearing the DTC

- The DTC will clear once an ignition cycle occurs without the fault recurring.
- The BCM history codes will clear once 100 concurrent ignition cycles occur without the fault recurring.
- Using a scan tool.

Diagnostic Aids

- Use a scan tool in order to inspect the Passlock(tm) data voltage and the Passlock(tm) code.
- Inspect for poor connections at the Passlock(tm) sensor. Refer to **Testing for Intermittent Conditions and Poor Connections** in Wiring Systems.

Test Description

The number below refers to the step number on the diagnostic table.

6: Tests for the proper operation of the circuit in the normal voltage range.

DTC B2960

Step	Action	Value (s)	Yes	No
Schematic Reference: Theft Deterrent System Schematics				
Connector End View Reference: Theft Deterrent System Connector End Views				
1	Did you perform the Vehicle Theft Deterrent (VTD) Diagnostic System Check?	-	Go to Step 2	Go to Diagnostic System Check - Theft Deterrent
2	<ol style="list-style-type: none"> 1. Install a scan tool. 2. Momentarily rotate the ignition switch to CRANK. Do not start the vehicle. 3. Release the ignition switch to ON. 4. Select the body control module (BCM) display DTCs function on the scan tool. 	-		Go to Testing for Intermittent Conditions

	Does the scan tool display DTC B2960 as a current DTC?		Go to Step 3	and Poor Connections in Wiring Systems
3	Does the scan tool display DTC B2947, B2948, B2957, or B2958?	-	Go to Diagnostic Trouble Code (DTC) List	Go to Step 4
4	Have you replaced the Passlock(tm) sensor on this vehicle?	-	Go to Step 5	Go to Step 6
5	Have you performed a Passlock(tm) learn procedure after replacing the Passlock(tm) sensor?	-	Go to Step 6	Go to Step 9
6	With a scan tool, observe the Passlock(tm) data voltage for one minute. Does the scan tool indicate that the Passlock (tm) data voltage is changing more than the specified value?	+/- 0.02 V	Go to Step 7	Go to Step 9
7	Inspect for poor connections at the Passlock (tm) sensor. Refer to Testing for Intermittent Conditions and Poor Connections and Connector Repairs in Wiring Systems. Did you find and correct the condition?	-	Go to Step 10	Go to Step 8
8	Replace the Passlock(tm) sensor in the electronic column lock module assembly. Refer to Ignition Lock Cylinder Replacement in Steering Wheel and Column. Did you complete the replacement?	-	Go to Step 9	-
9	Perform the Programming Theft Deterrent System Components procedure. Is the repair complete?	-	Go to Step 10	-
10	<ol style="list-style-type: none"> 1. Use the scan tool in order to clear the DTCs. 2. Turn OFF the ignition. <p>IMPORTANT: Do not start the vehicle.</p> <ol style="list-style-type: none"> 3. Momentarily rotate the ignition switch to CRANK. 4. Release the ignition switch to ON. 5. Select the body control module display DTCs function on the scan tool. 	-		
	Does the DTC reset?		Go to Step 3	System OK

DTC B3031

Circuit Description

The Passlock(tm) system is provided in order to prevent vehicle theft if the ignition lock cylinder is forced to rotate or the ignition switch is operated while separated from the ignition lock cylinder case. The body control module (BCM) provides security system sensor power and low reference for the Passlock(tm) sensor. The BCM also measures the security system sensor voltage.

When the correct key is used to start the vehicle, a magnet on the lock cylinder passes close to the Passlock(tm) sensor within the ignition lock cylinder case. The magnet activates the security hall effect sensor in the Passlock (tm) sensor which completes a circuit from the security sensor signal circuit through a resistor to the security sensor low reference circuit. The resistance value will vary from vehicle to vehicle. The BCM will measure the voltage on the security sensor signal circuit and compare this voltage to a previously learned voltage. If the voltage measured is within the valid range, the BCM will send a class 2 message to the powertrain control module (PCM) to enable vehicle starting. If the voltage measured is not within the valid range, a class 2 message will be sent to the PCM to disable starting of the vehicle.

Conditions for Setting the DTC

- A new BCM has been installed and the ignition is turned to the ON position but not rotated to the CRANK position. Once the ignition switch has been rotated to the CRANK position, the BCM will learn the Passlock(tm) code. The theft relearn procedure will need to be run in order to make the powertrain/vehicle control module (PCM/VCM) receive the correct fuel enable password.
- The BCM is in the learn mode but does not see a valid Passlock(tm) sensor code because of a sensor or a wiring problem.

Action Taken When the DTC Sets

The vehicle will not run. The security indicator will be ON.

Conditions for Clearing the MIL/DTC

- The DTC will clear after an ignition cycle has occurred after the BCM has learned a valid code.
- Using a scan tool.

Diagnostic Aids

- Prior to replacing a BCM, ensure that all of the diagnostics have been completed. Refer to **Diagnostic Trouble Code (DTC) List**.
- Inspect the Passlock(tm) sensor harness for intermittent or poor connections. Refer to **Testing for Intermittent Conditions and Poor Connections** in Wiring Systems.

Test Description

The number below refers to the step number on the diagnostic table.

3: Tests for the proper operation of the 12-volt reference Security Sensor Power circuit, sensor ground circuit, and Passlock(tm) sensor signal (data) circuit. Troubleshoot the appropriate DTC prior to diagnosing DTC B3031.

DTC B3031

Step	Action	Yes	No
Schematic Reference: Theft Deterrent System Schematics			
1	Did you perform the Vehicle Theft Deterrent (VTD) Diagnostic System Check?	Go to Step 2	Go to Diagnostic System Check - Theft Deterrent
2	<ol style="list-style-type: none"> 1. Install a scan tool. 2. Momentarily rotate the ignition switch to CRANK. Do not start the vehicle. 3. Release the ignition switch to ON. 4. Select the body control module display DTCs function on the scan tool. <p>Does the scan tool display DTC B3031 as a current DTC?</p>	Go to Step 3	Go to Step 4
3	Does the scan tool display DTC B2947, B2948, B2957, B2958, B2960, or B3033?	Go to Diagnostic Trouble Code (DTC) List	Go to Step 4
4	<ol style="list-style-type: none"> 1. Use the scan tool in order to clear the DTCs. 2. Turn OFF the ignition. 3. Start the vehicle. 4. Select the body control module display DTCs function on the scan tool. <p>Does the DTC reset?</p>	Go to Step 3	System OK

DTC B3033

Circuit Description

The Passlock(tm) system is provided in order to prevent vehicle theft if the ignition lock cylinder is forced to rotate or the ignition switch is operated while separated from the ignition lock cylinder case. The body control module (BCM) provides security system sensor power and low reference for the Passlock(tm) sensor. The BCM also measures the security system sensor voltage.

When the correct key is used to start the vehicle, a magnet on the lock cylinder passes close to the Passlock(tm) sensor within the ignition lock cylinder case. The magnet activates the security hall effect sensor in the Passlock (tm) sensor which completes a circuit from the security sensor signal circuit through a resistor to the security

sensor low reference circuit. The resistance value will vary from vehicle to vehicle. The BCM will measure the voltage on the security sensor signal circuit and compare this voltage to a previously learned voltage. If the voltage measured is within the valid range, the BCM will send a class 2 message to the powertrain control module (PCM) to enable vehicle starting. If the voltage measured is not within the valid range, a class 2 message will be sent to the PCM to disable starting of the vehicle.

Conditions for Setting the DTC

- The BCM will inspect for a tamper code when the ignition switch rotates from ON to CRANK and will continue to monitor the signal during the engine running period.
- The BCM is reading a tamper code from the Passlock(tm) sensor for longer than 1.0 seconds.

Action Taken When the DTC Sets

- The vehicle will not run. The security indicator will be flashing.
- The Passlock(tm) state is Tamper.

Conditions for Clearing the DTC

- The DTC will clear once an ignition cycle occurs without the fault recurring.
- The BCM history codes will clear after 100 ignition cycles occur without the fault recurring.
- Use a scan tool.

Diagnostic Aids

- Prior to replacing a BCM, ensure that all of the diagnostics have been completed. Refer to **Diagnostic Trouble Code (DTC) List**.
- Inspect the Passlock(tm) sensor harness for intermittent or poor connections. Refer to **Testing for Intermittent Conditions and Poor Connections** in Wiring Systems.
- The VTD internal diagnostics are not run while the tamper timer is active.

Test Description

The number below refers to the step number on the diagnostic table.

3: Tests for a magnetic field near the ignition lock cylinder.

DTC B3033

Step	Action	Yes	No
Schematic Reference: Theft Deterrent System Schematics			
Connector End View Reference: Theft Deterrent System Connector End Views			
1	Did you perform the Vehicle Theft Deterrent (VTD) Diagnostic System Check?	Go to Step 2	Go to Diagnostic System Check - Theft Deterrent
	1. Install a scan tool.		

2	<p>IMPORTANT: Do not start the vehicle.</p> <ol style="list-style-type: none"> 2. Momentarily rotate the ignition switch to CRANK. 3. Release the ignition switch to ON. 4. Select the body control module display DTCs function on the scan tool. <p>Does the scan tool display DTC B3033 as a current DTC?</p>	Go to Step 3	Go to Testing for Intermittent Conditions and Poor Connections in Wiring Systems
3	<p>Inspect the area around the ignition lock cylinder for any device which could create a magnetic field audio speaker, magnet, etc. Is there a magnetic device near the ignition lock cylinder?</p>	Go to Step 4	Go to Step 5
4	<p>Remove the device creating the magnetic force. Did you complete the repair?</p>	Go to Step 8	-
5	<p>Inspect for poor connections at the Passlock(tm) sensor. Refer to Testing for Intermittent Conditions and Poor Connections and Connector Repairs in Wiring Systems. Did you find and correct the condition?</p>	Go to Step 8	Go to Step 6
6	<p>Replace the Passlock(tm) sensor in the electronic column lock module assembly. Refer to Ignition Lock Cylinder Replacement in Steering Wheel and Column. Did you complete the replacement?</p>	Go to Step 7	-
7	<p>Perform the Programming Theft Deterrent System Components procedure. Is the repair complete?</p>	Go to Step 8	-
8	<p>IMPORTANT: You may have to wait up to 10 minutes in order to reset the BCM and synchronize all of the Passlock(tm) components.</p> <ol style="list-style-type: none"> 1. Use the scan tool in order to clear the DTCs. 2. Turn OFF the ignition. <p>IMPORTANT: Do not start the vehicle.</p> <ol style="list-style-type: none"> 3. Momentarily rotate the ignition switch to CRANK. 4. Release the ignition switch to ON. 5. Select the body control module display DTCs function on the scan tool. <p>Does the DTC reset?</p>	Go to Step 3	System OK

DTC P1626

Circuit Description

The control module communicates with other modules using the class 2 serial data circuit. The vehicle theft deterrent (VTD) body control module (BCM) sends a vehicle security password to the powertrain control module (PCM), via the class 2 serial data circuit, after the BCM has sensed the proper operation of the ignition switch and lock, and determined that the switch and lock have not been tampered with. If this password matches the password stored in the PCM, fuel will be enabled. If the BCM does not send a password, or if the PCM does not receive it, the vehicle will not start, or it may start and stall. This will set a DTC P1626 in the PCM memory. If communication is lost after receiving the password, the VTD Passlock(tm) system will go into Fail Enable, set a U1192 in the PCM memory, and the engine will continue to run. This will allow the engine to restart on future ignition cycles but may set a DTC P1626 as the engine is started. If the battery is disconnected or the codes are cleared, the vehicle will lose its Fail Enable status and will not start until communication is re-established.

Conditions for Running the DTC

- The vehicle theft deterrent (VTD) system is enabled.
- The fuel enable decision point has been reached, or the engine is cranking.

Conditions for Setting the DTC

The powertrain control module (PCM) has not established communications with the body control module (BCM) and has not received a valid password before the fuel disable decision point was reached.

Action Taken When the DTC Sets

- The powertrain control module (PCM) stores the DTC in history after the first failure but will not illuminate the malfunction indicator lamp (MIL).
- The powertrain control module (PCM) records the operating conditions at the time the diagnostic fails. The PCM stores the failure information in the scan tools Freeze Frame/Failure Records.

Conditions for Clearing the MIL/DTC

- A history DTC will clear if no fault conditions have been detected for 40 warm-up cycles.
- A warm-up cycle occurs when the coolant temperature has risen 22°C (40°F) from the startup coolant temperature and the engine coolant temperature exceeds 70°C (160°F) during the same ignition cycle.
- Use the scan tool Clear Information function.

Diagnostic Aids

IMPORTANT: Do not clear DTCs unless directed by a diagnostic procedure. Clearing DTCs will also clear valuable Freeze Frame and Failure Records data.

- Check for published service bulletins relating to exhibited symptoms or component operation.

- Inspect all related wiring and connections including the powertrain control module (PCM) and body control module (BCM) connections. These may cause an intermittent malfunction.
- If the class 2 serial data circuit is shorted to ground or shorted to voltage, then all systems connected to the serial data circuit will not be able to communicate properly. Systems capable of storing loss of communications DTCs, or the DTCs with the letter "U" as a prefix, will have these codes stored in their memory. If a DTC U1192 is stored in the PCM memory along with the P1626, then a fault occurred at some point after the PCM received the correct password. The BCM must also be checked for intermittent operation due to a loss of power or ground to the module itself. After repairing the cause of DTC 1626, clear all DTCs from the systems capable of storing this DTC and DTC U1192.
- The VTD Passlock(tm) parameters can be monitored in the PCM under engine data 2, display with a scan tool.
- The scan tool Diagnostic Circuit Check can be used to:
 - Monitor the class 2 serial data circuit for modules which have been or are communicating.
 - Monitor for loss of communications DTCs with the letter "U" as a prefix: U1001-U1199.
 - Clear loss of communication DTCs. When a Clear Codes command is issued, all codes, Freeze Frame and Failure Records information is cleared.
- The scan tool Class 2 Message Monitor will show the status of each module on the class 2 circuit. A status of Active indicates that the module is communicating with the scan tool. An inactive status indicates that the module previously communicated with the scan tool, but is not communicating currently. The inactive status will only appear if the loss of communication occurs while on the message monitor screen. If a module is not listed at all, then the missing module never successfully established communications with the scan tool or lost communication while on another screen. Refer to **Scan Tool Does Not Communicate with Class 2 Device** in Data Link Communications for the complete class 2 data link to determine if there are any unlisted modules.

An intermittent may be caused by any of the following conditions:

- A poor connection
- Rubbed through wire insulation
- A broken wire inside the insulation

Thoroughly inspect any circuitry that is suspected of causing the intermittent complaint. Refer to **Testing for Intermittent Conditions and Poor Connections** in Wiring Systems.

If a repair is necessary, refer to **Wiring Repairs** or **Connector Repairs** in Wiring Systems.

Test Description

The numbers below refer to the step numbers on the diagnostic table.

2: This test checks if communications can be established between the scan tool and the body control module (BCM). If the scan tool cannot communicate with the BCM, refer to **Diagnostic System Check - Theft Deterrent**.

3: This test checks for any opens in the serial data circuit between the powertrain control module (PCM)

and the BCM. This also checks for any intermittent malfunctions associated with the serial data circuit.

4: This step is to determine if the condition that set the DTC is still present. The engine must be cranked in order to set this DTC. If the condition is present, the engine will start and then stall, indicating the PCM is disabling fuel.

7: Use a scan tool to clear and check for any DTCs in all the modules connected to the class 2 serial data circuit, such as the PCM, BCM, automatic temperature control (ATC), and body control module (BCM).

DTC P1626 Loss of Serial Communication with VTD

Step	Action	Yes	No
Schematic Reference: <u>Data Link Connector (DLC) Schematics (A/T)</u> or <u>Data Link Connector (DLC) Schematics (M/T)</u>			
1	Did you perform the Vehicle Theft Deterrent Diagnostic System Check?	Go to Step 2	Go to <u>Diagnostic System Check - Theft Deterrent</u>
2	<p>IMPORTANT: You must diagnose the Bxxxx codes prior to diagnosing any Pxxxx code.</p> <ol style="list-style-type: none"> 1. Install a scan tool. <p>IMPORTANT: Do not start the vehicle.</p> <ol style="list-style-type: none"> 2. Momentarily rotate the ignition switch to CRANK. 3. Release the ignition switch to ON. 4. Select the powertrain control module display DTCs function on the scan tool. <p>Does the scan tool display DTC P1626 as a current DTC?</p>	Go to Step 3	Go to <u>Testing for Intermittent Conditions and Poor Connections</u> in Wiring Systems
3	<p>Check the class 2 serial data circuit for the following intermittent conditions:</p> <ul style="list-style-type: none"> • An open in the class 2 serial data circuit between the PCM and the BCM • A short to ground • A short to voltage • Loose or damaged terminals at the DLC, PCM, or the BCM <p>Did you find a problem?</p>	Go to Step 6	Go to Step 4
	1. Turn OFF the ignition.		

4	<ol style="list-style-type: none"> 2. Connect or install any connectors or components that were disconnected or removed. 3. Clear all DTCs using a scan tool. 4. Turn OFF the ignition for 15 seconds. 5. Attempt to start the engine. <p>Does DTC P1626 reset?</p>	Go to Step 8	Go to Step 5
5	<p>This DTC is intermittent. Are any additional DTCs stored?</p>	Go to the applicable DTC table	Go to Testing for Intermittent Conditions and Poor Connections in Wiring Systems
6	<p>Repair the circuit as necessary. Refer to Wiring Repairs or Connector Repairs in Wiring Systems. Is the action complete?</p>	Go to Step 7	-
7	<p>IMPORTANT: Before clearing DTCs, monitor all DTC status parameters and note any additional DTCs.</p> <ol style="list-style-type: none"> 1. Turn OFF the ignition. 2. Connect or install any connectors or components that were disconnected or removed. 3. Clear all PCM DTCs using a scan tool. 4. Turn OFF the ignition for 15 seconds. 5. Start the engine and allow it to run. <p>Does the DTC reset?</p>	Go to Step 2	System OK
8	<p>Inspect for poor connections at the BCM. Refer to Testing for Intermittent Conditions and Poor Connections and Connector Repairs in Wiring Systems. Did you find and correct the condition?</p>	Go to Step 7	Go to Step 9
9	<p>IMPORTANT: When replacing the BCM, refer to <u>Body Control Module (BCM) Programming/RPO Configuration in Body Control System.</u></p> <p>Replace the body control module. Refer to Body Control Module Replacement in Body Control System. Did you complete the replacement?</p>	Go to Step 7	-

Circuit Description

The powertrain control module (PCM) controls the fuel injector operation based on a vehicle theft deterrent (VTD) password from the vehicle body control module (BCM). When the ignition is first turned ON, the BCM sends a programmed theft deterrent password to the PCM. The PCM acknowledges the password and responds to the BCM that normal fuel injector operation will continue. When starting the engine, the PCM looks for a password from the BCM through the Class 2 serial data circuit. If the password is not recognized or not present, the PCM will disable the engine. If an incorrect or no password is received, fuel enable will not occur and the engine will not start. The Security indicator will flash on the instrument panel cluster (IPC) for approximately 4 seconds. If an incorrect or no password is received more than three times, this indicates that the engine is disabled for at least 10 minutes and that the Security indicator will illuminate solid on the IPC for approximately 3 seconds then flash on the IPC for 10 minutes. If the PCM loses communication with the BCM within the same ignition cycle, the vehicle will be enter fail-enable mode and continue to run on the following ignition cycles.

Conditions for Running the DTC

The ignition is cycled to ON.

Conditions for Setting the DTC

The PCM receives an incorrect fuel enable password from the BCM.

The PCM receives no password from the BCM.

Action Taken When the DTC Sets

- The PCM will record operating conditions at the time during which the diagnostic fails. This information will be stored in the Freeze Frame and Failure Records buffers.
- The fuel system is disabled by the PCM.

Conditions for Clearing the MIL/DTC

- A history DTC will clear after 40 consecutive warm up cycles without a fault.
- A scan tool can clear current and history DTCs.

Diagnostic Aids

Attempting to start the vehicle by bypassing the Passlock system or by substituting parts without performing the Programming Theft Deterrent System Components procedure may set a DTC P1631.

If no password is received, a DTC U1064 may be set.

Test Description

The number below refers to the step number on the diagnostic table.

4: The scan tool displays the actual voltage code from the Passlock cylinder. This voltage should be within 0-5 volts. If it is not, a theft deterrent B code will be set and should be diagnosed first.

DTC P1629

Step	Action	Yes	No
1	Did you perform A Diagnostic System Check-Theft Deterrent?	Go to Step 2	Go to <u>Diagnostic System Check - Theft Deterrent</u>
2	<ol style="list-style-type: none"> 1. Install a scan tool. 2. Turn ON the ignition with the engine OFF. 3. Select the Display DTCs function for the PCM. Does the scan tool display DTC P1626 or DTC P1631?	Go to <u>Diagnostic Trouble Code (DTC) List</u>	Go to Step 3
3	<ol style="list-style-type: none"> 1. Perform the Programming Theft Deterrent System Components Procedure. Refer to <u>Programming Theft Deterrent System Components</u> . 2. Attempt to start the engine. Does the engine start and continue to run?	Go to Step 8	Go to Step 4
4	<ol style="list-style-type: none"> 1. Display the Security Data list for the BCM. 2. Observe the PASSLOCK DATA VOLTAGE parameter. Does the scan tool indicate that the Passlock(tm) Data voltage is within 0-5 volts?	Go to Step 5	Go to Step 6
5	IMPORTANT: When replacing the PCM, perform the programming procedure. Refer to <u>Service Programming System (SPS) in Vehicle Control Systems/Programming</u> . Replace the PCM. Refer to <u>Engine Control Module (ECM) Replacement</u> or <u>Powertrain Control Module (PCM) Replacement</u> .Did you complete the replacement?	Go to Step 8	-
6	Invalid data will set a theft deterrent B code. Refer to <u>Diagnostic Trouble Code (DTC) List</u> . Are there any theft deterrent B-codes set?	Go to <u>Diagnostic Trouble Code (DTC) List</u>	Go to Step 7
7	IMPORTANT: When replacing the BCM, perform the setup procedure. Refer to <u>Body Control Module (BCM) Programming/RPO Configuration in Body Control System</u> .		

	Replace the BCM. Refer to Body Control Module Replacement in Body Control System. Did you complete the replacement?	Go to Step 8	-
8	<ol style="list-style-type: none"> Using the scan tool, clear the DTCs. Start the engine. Idle the engine at the normal operating temperature. <p>Does the DTC reset?</p>	Go to Step 2	System OK

DTC P1630

Circuit Description

The vehicle theft deterrent system (VTD) is incorporated within the body control module (BCM). If the BCM has been replaced, the password must be relearned. If the powertrain control module (PCM) is replaced, the replacement PCM should learn the password within a few seconds after the ignition is turned ON. This is an information code indicating that the PCM is ready to learn the VTD password.

Conditions for Running the DTC

- The VTD system has allowed fuel delivery.
- The PCM is in the theft deterrent password learn mode.

Conditions for Setting the DTC

The PCM remains in theft deterrent password learn mode for more than 2 seconds.

Action Taken When the DTC Sets

- The PCM will not illuminate the malfunction indicator lamp (MIL).
- The PCM will store conditions which were present when the DTC set as failure records data only. This information will not be stored as freeze frame data.
- The Service Vehicle Soon (SVS) light may be illuminated.

Conditions for Clearing the DTC/MIL

- A history DTC will clear after 40 consecutive warm-up cycles have occurred without a malfunction.
- The DTC can be cleared by using a scan tool.

Diagnostic Aids

A new replacement PCM will be in a functional state to learn the password from the BCM. If the BCM is replaced, the PCM must be placed in password learning mode to relearn a new password. Once learned, the password becomes permanent information that remains with the vehicle. The loss of PCM battery or ignition voltage will not affect the programmed password information.

DTC P1630

Step	Action	Yes	No
1	Did you perform A Diagnostic System Check-Theft Deterrent?	Go to Programming Theft Deterrent System Components	Go to Diagnostic System Check - Theft Deterrent

DTC P1631

Circuit Description

The Class 2 Serial Data circuit is used in order to communicate between the powertrain control module (PCM) and the vehicle theft deterrent body control module (BCM) systems.

When the Passlock portion of the VTD system has sensed the proper operation of the ignition switch and lock, or determined that the switch and lock have not been tampered with, the BCM transmits a password to the PCM. Fuel delivery is enabled if this password matches the password stored in the modules memory. If a component in the theft deterrent system has been replaced, the modules need to relearn the password of the new components. If the relearn procedure was not performed, this diagnostic trouble code (DTC) will set.

If a VTD failure occurs during an ignition cycle that the PCM has enabled fuel, then the BCM will enter a fail-safe mode: Fail Enable VTD System Failure with Fuel Enabled. The BCM remains in Fail Enable Mode, for the current and future ignition cycles, until the fault is corrected and a valid password is received, or until battery power is removed. If the battery is disconnected or the codes are cleared, the vehicle will lose its Fail Enable status and will not start until the fault is corrected, the ten minute timer expires, and the PCM receives the correct fuel delivery password.

Conditions for Running the DTC

- DTC P1626 is not active.
- The powertrain control module (PCM) is not in password learn mode.
- The VTD Passlock system is enabled.
- The fuel enable decision point has been reached, or the engine is cranking.

Conditions for Setting the DTC

The powertrain control module (PCM) did not receive a valid password before the fuel disable decision point was reached.

Action Taken When the DTC Sets

- The powertrain control module (PCM) stores the DTC in history after the first failure but will not illuminate the malfunction indicator lamp (MIL).
- The PCM records the operating conditions at the time the diagnostic fails. The PCM stores the failure information in the scan tools Freeze Frame/Failure Records.
- The Service Vehicle Soon (SVS) light may be illuminated.

Conditions for Clearing the MIL/DTC

- A history DTC will clear if no fault conditions have been detected for 40 warm-up cycles.
- A warm-up cycle occurs when the coolant temperature has risen 22°C (40°F) from the startup coolant temperature and the engine coolant temperature exceeds 70°C (160°F) during the same ignition cycle.
- Use the scan tool Clear Information function.

Diagnostic Aids

IMPORTANT: Do not clear DTCs unless directed by a diagnostic procedure. Clearing DTCs will also clear valuable Freeze Frame and Failure Records data.

- If the powertrain control module (PCM) is replaced, the PCM must re-learn a valid password and crankshaft variation.
- If the body control module (BCM) is replaced, the PCM must re-learn a valid password.
- Check for published service bulletins relating to exhibited symptoms or component operation.
- If the vehicle does not start, or starts and stalls:
 - Turn OFF the ignition and wait at least 5 seconds before trying to restart.
 - If a fault or tamper has been detected, the BCM will not forward the correct password to the PCM for a period of ten minutes, even if the condition is corrected during that time period. This may cause a DTC P1631 to set in the PCM. This timer can be monitored in the Passlock Data parameter of the scan tool. Once the time has elapsed, the BCM will determine if the condition is still present.
- The PCM and BCM parameters can be monitored with a scan tool.
- The Passlock state and the auto learn timer can be viewed in the Passlock Data parameter of the scan tool.
- Check the following for preventing the Passlock sensor from communicating with the BCM:
 - Passlock sensor
 - Ignition switch assembly
 - Passlock sensor circuitry
 - Bent pins at the small Passlock sensor
- If this DTC sets along with a DTC B2960, then the problem was caused by malfunctioning Passlock components or circuitry, not the PCM.
- Inspect all related wiring and connections including the PCM and BCM connections. These may cause an intermittent malfunction.

An intermittent may be caused by any of the following conditions:

- A poor connection
- Rubbed through wire insulation
- A broken wire inside the insulation

Thoroughly inspect any circuitry that is suspected of causing the intermittent complaint. Refer to **Testing for Intermittent Conditions and Poor Connections** in Wiring Systems.

If a repair is necessary, refer to **Wiring Repairs or Connector Repairs** in Wiring Systems.

Test Description

The numbers below refer to the step numbers on the diagnostic table.

2: This DTC may set as a result of other Passlock System problems. Diagnose any BCM DTCs prior to continuing with this diagnostic.

3: A DTC B3031 may set in the body control module (BCM) during the Password Learn Procedure.

DTC P1631

Step	Action	Yes	No
Schematic Reference: <u>Data Link Connector (DLC) Schematics (A/T)</u> or <u>Data Link Connector (DLC) Schematics (M/T)</u>			
1	Did you perform the Vehicle Theft Deterrent (VTD) Diagnostic System Check?	Go to Step 2	Go to <u>Diagnostic System Check - Theft Deterrent</u>
2	IMPORTANT: You must diagnose the Bxxxx codes prior to diagnosing any Pxxxx code. 1. Install a scan tool. 2. Momentarily rotate the ignition switch to CRANK. Do not start the vehicle. 3. Release the ignition switch to ON. 4. Select the powertrain control module (PCM) display DTCs function on the scan tool. Does the scan tool display DTC P1631 as a current DTC?	Go to Step 3	Go to <u>Testing for Intermittent Conditions and Poor Connections in Wiring Systems</u>
3	Perform the Passlock Programming procedure. Refer to <u>Programming Theft Deterrent System Components</u> . Did the PCM successfully learn the password?	Go to Step 4	Go to <u>Diagnostic System Check - Theft Deterrent</u>
4	IMPORTANT: Before Clearing DTCs, monitor all DTC status parameters and note any additional DTCs. 1. Clear the PCM DTCs. 2. Turn OFF the ignition for 30 seconds. 3. Attempt to start the engine. Does the engine start and operate normally?	System OK	Go to Step 2

SYMPTOMS - THEFT DETERRENT

Important Preliminary Checks Before Starting

1. Perform the **Diagnostic System Check - Theft Deterrent** before using the Symptom Tables in order to verify that all of the following are true:
 - There are no DTCs set.
 - The control modules can communicate via the serial data link.
2. Review the vehicle theft deterrent description and operation in order to familiarize yourself with the system functions. Refer to **Vehicle Theft Deterrent (VTD) Description and Operation** .

Visual/Physical Inspection

- Inspect for aftermarket devices which could affect the operation of the Passlock(tm) system. Refer to **Checking Aftermarket Accessories** in Wiring Systems.
- Inspect the easily accessible or visible system components for obvious damage or conditions which could cause the symptom.

Intermittent

Faulty electrical connections or wiring may be the cause of intermittent conditions. Refer to **Testing for Intermittent Conditions and Poor Connections** in Wiring Systems.

Symptom List

Refer to a symptom diagnostic procedure from the following list in order to diagnose the symptom:

- **Content Theft Deterrent (CTD) Alarm Mode Inoperative**
- **Horn Inoperative in Content Theft Deterrent (CTD) Alarm Mode**
- **Lights Inoperative in Content Theft Deterrent (CTD) Alarm Mode**
- **Security Indicator Always On or Flashing**
- **Security Indicator Inoperative**

CONTENT THEFT DETERRENT (CTD) ALARM MODE INOPERATIVE

Content Theft Deterrent (CTD) Alarm Mode Inoperative

Step	Action	Yes	No
Schematic Reference: <u>Theft Deterrent System Schematics</u> Connector End View Reference: <u>Theft Deterrent System Connector End Views</u> DEFINITION: The CTD system will not ARM or DISARM properly.			
1	Did you perform A Diagnostic System Check - Theft Deterrent?	Go to Step 2	Go to <u>Diagnostic System Check - Theft Deterrent</u>
	1. Open the driver and passenger windows. 2. Unlock the doors using the keyless		

2	<p>entry transmitter.</p> <ol style="list-style-type: none"> 3. Remove the keys from the ignition. 4. Open the driver's door. 5. Observe the courtesy lamps. <p>Do the courtesy lamps illuminate?</p>	Go to Step 3	Go to Courtesy Lamps Inoperative in Lighting Systems
3	<ol style="list-style-type: none"> 1. Open the driver and passenger windows. 2. Unlock the doors using the keyless entry transmitter. 3. Remove the keys from the ignition. 4. Open the driver's door. 5. Observe the theft LED. <p>Is the theft system LED on steady or flashing?</p>	Go to Security Indicator Always On or Flashing	Go to Step 4
4	<ol style="list-style-type: none"> 1. Lock the vehicle using the power door lock switches or the keyless entry transmitter. 2. Observe the theft LED. <p>After 30 seconds, does the theft LED change from OFF to FLASHING?</p>	Go to Step 5	Go to Power Door Locks Inoperative - All Doors and Switches in Doors
5	<ol style="list-style-type: none"> 1. Close all of the doors. <p>IMPORTANT: Ensure that all the doors are closed. The Content Theft Deterrent System will not arm if all of the doors are not closed.</p> <ol style="list-style-type: none"> 2. Observe the theft LED. <p>Does the theft LED begin to flash slowly in about 10 seconds?</p>	Go to Step 6	Go to Courtesy Lamps Always On in Lighting Systems
6	<ol style="list-style-type: none"> 1. Reach in and unlock the driver's door manually. 2. Open the driver's door. <p>After approximately 10 seconds, do all of the alarm mode functions activate-parking lights flash and horn pulses?</p>	Go to Step 7	Go to Step 8

7	Disarm the CTD system by using the keyless entry transmitter. Do all of the alarm mode functions stop?	Go to <u>Testing for Intermittent Conditions and Poor Connections</u> in Wiring Systems	Go to <u>Keyless Entry System Inoperative</u> in Keyless Entry
8	Do any of the alarm functions activate?	Go to Step 9	Go to <u>Courtesy Lamps Inoperative</u> in Lighting Systems
9	Do the horns pulse only?	Go to <u>Lights Inoperative in Content Theft Deterrent (CTD) Alarm Mode</u>	Go to <u>Horn Inoperative in Content Theft Deterrent (CTD) Alarm Mode</u>

HORN INOPERATIVE IN CONTENT THEFT DETERRENT (CTD) ALARM MODE

Horn Inoperative in Content Theft Deterrent (CTD) Alarm Mode

Step	Action	Yes	No
Schematic Reference: <u>Theft Deterrent System Schematics</u>			
Connector End View Reference: <u>Theft Deterrent System Connector End Views</u>			
DEFINITION: The horn does not sound when the CTD system is in alarm mode.			
1	Did you perform the Theft Deterrent Diagnostic System Check?	Go to Step 2	Go to <u>Diagnostic System Check - Theft Deterrent</u>
2	<ol style="list-style-type: none"> 1. Install a scan tool. 2. Turn ON the ignition with the engine OFF. 3. With the scan tool, command the horn relay ON. Does the horn sound?	Go to <u>Testing for Intermittent Conditions and Poor Connections</u> in Wiring Systems	Go to Step 3
3	Press the horn switch on the steering wheel. Does the horn sound?	Go to Step 4	Go to <u>Horns Inoperative</u> in Horns
4	<ol style="list-style-type: none"> 1. Disconnect the body control module (BCM) connector containing the horn relay control circuit. 2. With a fused jumper wire and appropriate terminal adapter, ground the horn relay control circuit. Does the horn sound?	Go to Step 6	Go to Step 5
5	Test the horn relay control circuit for an open or short to battery. Refer to <u>Circuit Testing</u> and <u>Wiring Repairs</u> in Wiring Systems. Did you find and correct the condition?	Go to Step 8	Go to <u>Testing for Intermittent Conditions and Poor Connections</u> in Wiring Systems
	Inspect for poor connections at the harness connector of the BCM. Refer to <u>Testing for</u>		

6	Intermittent Conditions and Poor Connections and Connector Repairs in Wiring Systems. Did you find and correct the condition?	Go to Step 8	Go to Step 7
7	Replace the BCM. Refer to Body Control Module Replacement in Body Control System. IMPORTANT: Perform the setup procedure for the BCM. Did you complete the replacement?	Go to Step 8	-
8	Operate the system in order to verify the repair. Did you correct the condition?	System OK	Go to Step 3

LIGHTS INOPERATIVE IN CONTENT THEFT DETERRENT (CTD) ALARM MODE

Lights Inoperative in Content Theft Deterrent (CTD) Alarm Mode

Step	Action	Yes	No
Schematic Reference: <u>Theft Deterrent System Schematics</u>			
Connector End View Reference: <u>Theft Deterrent System Connector End Views</u>			
DEFINITION: The vehicle lights do not flash when the CTD system is in alarm mode.			
1	Did you perform A Diagnostic System Check - Theft Deterrent?	Go to Step 2	Go to Diagnostic System Check - Theft Deterrent
2	Perform one of the following to activate the CTD alarm mode: <ul style="list-style-type: none"> • Operate the PANIC button on the keyless entry transmitter. • Complete the following steps: <ol style="list-style-type: none"> 1. Open the driver's window. 2. Lock the vehicle using the power door lock switch. 3. Close all of the doors and wait at least 30 seconds. 4. Reach in and unlock the driver's door manually. 5. Open the driver's door. 		

	Do all of the alarm mode functions activate-lights flash and horn pulses?	Go to <u>Testing for Intermittent Conditions and Poor Connections</u> in Wiring Systems	Go to Step 3
3	Are only the head lamps inoperative?	Go to <u>Headlamps Inoperative - Low and High Beams</u> in Lighting Systems	Go to <u>Content Theft Deterrent (CTD) Alarm Mode Inoperative</u>

SECURITY INDICATOR ALWAYS ON OR FLASHING

Security Indicator Always On or Flashing

Step	Action	Yes	No
Schematic Reference: <u>Theft Deterrent System Schematics</u>			
Connector End View Reference: <u>Theft Deterrent System Connector End Views</u>			
1	Did you perform the Theft Deterrent Diagnostic System Check?	Go to Step 2	Go to <u>Diagnostic System Check - Theft Deterrent</u>
2	<ol style="list-style-type: none"> 1. Turn ON the ignition with the engine OFF. 2. With the scan tool, command the Security indicator ON and OFF. <p>Does the Security indicator turn ON and OFF with each command?</p>	Go to <u>Testing for Intermittent Conditions and Poor Connections</u> in Wiring Systems	Go to Step 3
3	<p>Replace the Instrument Cluster. Refer to <u>Instrument Panel Cluster (IPC) Replacement</u> in Instrument Panel, Gages and Console.</p> <p>Did you complete the replacement?</p>	Go to <u>Diagnostic System Check - Instrument Cluster</u> in Instrument Panel, Gages and Console	-

SECURITY INDICATOR INOPERATIVE

Security Indicator Inoperative

Step	Action	Yes	No
Schematic Reference: <u>Theft Deterrent System Schematics</u>			
Connector End View Reference: <u>Theft Deterrent System Connector End Views</u>			
1	Did you perform the Theft Deterrent Diagnostic System Check?	Go to Step 2	Go to <u>Diagnostic System Check - Theft Deterrent</u>
2	<ol style="list-style-type: none"> 1. Turn ON the ignition with the engine OFF. 2. With the scan tool, command the Security indicator ON and OFF. 		

	Does the Security indicator turn ON and OFF with each command?	Go to <u>Testing for Intermittent Conditions and Poor Connections</u> in Wiring Systems	Go to Step 3
3	Replace the Instrument Cluster. Refer to <u>Instrument Panel Cluster (IPC) Replacement</u> in Instrument Panel, Gages and Console. Did you complete the replacement?	Go to <u>Diagnostic System Check - Instrument Cluster</u> in Instrument Panel, Gages and Console	-

REPAIR INSTRUCTIONS

ADDING KEYS

The ignition lock cylinder and keys do not contain any coded electronic components. The lock cylinder housing contains the coded electronic components. Changing an ignition lock cylinder or adding a key is a purely mechanical process which does not affect the vehicle theft deterrent system. To add a key, simply cut a new key to match the existing one. To change the lock cylinder, simply replace the existing lock cylinder with one of the same type.

PROGRAMMING THEFT DETERRENT SYSTEM COMPONENTS

Programming Replacement Passlock(tm) Sensor, BCM, or PCM

IMPORTANT:

- The body control module (BCM) must be programmed with the proper RPO configurations before performing learn procedures. See **Body Control Module (BCM) Programming/RPO Configuration** .
- If replacing the BCM with a GM Service Parts Operations (SPO) replacement part, the module will learn passlock(tm) sensor data code immediately. The existing PCM however, must learn the new fuel continue password when the BCM is replaced.
- If replacing a PCM with a GM Service Parts Operations (SPO) replacement part, after programming, these modules will learn the incoming fuel continue password immediately upon receipt of a password message. Once a password message is received, and a password is learned, a learn procedure must be performed to change this password again. A PCM which has been previously installed in another vehicle will have learned the other vehicle's fuel continue password and will require a learn procedure after programming to learn the current vehicle's password.

Conditions

Use this procedure after replacing:

- Passlock(tm) Sensor
- BCM

- PCM

Learn Procedures

There are two available methods to perform the programming procedure:

- A 10 minutes procedure which requires a Tech 2 and a techline terminal.
- A 30 minutes procedure which does not require the use of any tools.

10 Minute Learn Procedure

Tools Required

- Tech 2
- Techline terminal with current Service Programming System (SPS) software

1. Connect the Tech 2 to the vehicle.
2. Select "Request Information" under "Service Programming".
3. Disconnect the Tech 2 from the vehicle and connect it to a techline terminal.
4. On the techline terminal, select "Theft Module Re-Learn" under "Service Programming".
5. Disconnect the Tech 2 from the techline terminal and connect it to the vehicle.
6. Turn ON the ignition, with the engine OFF.
7. Select "VTD Re-Learn" under "Service Programming".
8. Attempt to start the engine, then release the key to ON, vehicle will not start.
9. Observe the SECURITY telltale, after approximately 10 minutes the telltale will turn OFF, the vehicle is now ready to relearn the Passlock(tm) Sensor Data Code and/or password on the next ignition switch transition from OFF to CRANK.
10. Turn OFF the ignition, and wait 5 seconds.
11. Start the engine, the vehicle has now learned the password.
12. With the Tech 2 scan tool, clear any DTCs.

30 Minute Learn Procedure

1. Turn ON the ignition, with the engine OFF.
2. Attempt to start the engine, then release the key to ON, vehicle will not start.
3. Observe the SECURITY telltale, after approximately 10 minutes the telltale will turn OFF.
4. Turn OFF the ignition, and wait 5 seconds.
5. Repeat steps 1 through 4 two more times for a total of 3 cycles/30 minutes, the vehicle is now ready to relearn the Passlock(tm) Sensor Data Code and/or passwords on the next ignition switch transition from OFF to CRANK.

IMPORTANT: The vehicle learns the Passlock(tm) Sensor Data Code and/or password

on the next ignition switch transition from OFF to CRANK. You must turn the ignition OFF before attempting to start the vehicle.

6. Start the engine. The vehicle has now learned the Passlock(tm) Sensor Data Code and/or password.
7. With a scan tool, clear any DTCs if needed. History DTCs will self clear after 100 ignition cycles.

DESCRIPTION AND OPERATION

THEFT SYSTEMS DESCRIPTION AND OPERATION

Theft System Description and Operation

The theft deterrent system on this vehicle is comprised of two separate systems, the vehicle theft deterrent (VTD) system and the content theft deterrent (CTD) system. VTD prevents drive away theft by keeping the vehicle from starting. CTD is the vehicle alarm system which discourages unauthorized entry into the vehicle. These system are described and diagnosed separately within this section.

SECURITY Telltale

The SECURITY Telltale on the message center is controlled by both the VTD system and the CTD system. The SECURITY telltale is a part of the reconfigurable message center on the instrument cluster. The SECURITY telltale is controlled by the body control module through the class 2 data line.

- The VTD system contained in the BCM commands the instrument cluster to control the SECURITY telltale only when the ignition switch is ON. The VTD system uses the telltale as a malfunction indicator.
- The CTD system also contained in the BCM commands the instrument cluster to control the indicator only when the ignition switch is OFF. The CTD system uses the SECURITY telltale to identify system status.

Theft Lock Radio (if applicable)

Refer to **Diagnostic Starting Point - Entertainment** in Entertainment.

CTD/VTD Description and Operation

Refer to the following for the appropriate description and operation:

- **Content Theft Deterrent (CTD) Description and Operation**
- **Vehicle Theft Deterrent (VTD) Description and Operation**

CONTENT THEFT DETERRENT (CTD) DESCRIPTION AND OPERATION

The Content Theft Deterrent (CTD) System, when armed, is designed to deter vehicle content theft by pulsing the horns and exterior lamps for approximately 2 minutes when an unauthorized vehicle entry is detected. However, the CTD System does not affect engine starting.

An unauthorized entry can be any of the following with the CTD System armed:

- When any door is opened without being unlocked by using the keyless entry transmitter to unlock the doors.
- When opening a door or the trunk with the correct key without disarming the CTD System.

The components of the system are:

- Body control module
- Door ajar switches

Arming the CTD System

IMPORTANT: The content theft deterrent (CTD) System can be armed with the windows or sunroof open.

Use the following procedure in order to arm the system:

1. Place the shift lever in P (park).
2. Turn OFF the ignition.
3. Open any door.

IMPORTANT: The system is not armed if the doors are locked manually, the remote keyless entry transmitter must be used to arm the CTD System.

4. Lock the doors with the LOCK button on the transmitter. The system is in arm pending mode and will not start the arming timer until all doors are closed. The security indicator will remain OFF, until the CTD System is armed. The CTD System will arm after the last door is closed.
5. The system will arm approximately 30 seconds from the time that the last door is closed. During this delay the THEFT SYSTEM indicator will be OFF. When the indicator transitions to FLASHING, the system is armed.

Locking The Vehicle Without Arming The CTD System

Locking the vehicle may be accomplished without arming the Content Theft Deterrent (CTD) System. Use of the manual door locks or using the key to lock the doors will lock the vehicle but will not arm the CTD System.

Disarming an Armed System/Silencing an Alarm

If system arming has been requested by the keyless entry transmitter, it must be disarmed.

IMPORTANT: Using the power door unlock switch or manually unlocking the doors does not disable the Content Theft Deterrent (CTD) armed mode. Also, disconnecting the battery or pulling fuses does not disable the armed mode, since the body control module (BCM) stores the CTD mode status in memory.

- To disarm the CTD System in arm pending mode, SECURITY indicator flashing and doors open, perform one of the following:
 - Press the UNLOCK button on the keyless entry transmitter.
 - Insert a valid key into the ignition and start the vehicle.
- To disarm the CTD System in the armed mode:
 - Press the UNLOCK button on the keyless entry transmitter.
 - Insert a valid key into the ignition and start the vehicle.
- To disarm the CTD System when activated, alarming mode.
 - Press the UNLOCK button on the keyless entry transmitter.
 - Insert a valid key into the ignition and start the vehicle.

CTD Circuit Description

The following is a description of each component used in the Content Theft Deterrent (CTD) System:

Body Control Module (BCM)

The CTD system is an internal function of the body control module (BCM) which utilizes class 2 serial data and various switch input information to perform CTD functions. When the BCM detects an unauthorized entry, it activates the horns and exterior lamps.

When the BCM detects an unauthorized entry, the BCM enters the alarm mode. The BCM activates the horns and exterior lamps for 2 minutes. This is followed by a three minute time-out with the horn no longer active. If no new intrusions are detected after the time-out, the horn is not active. The system must be disarmed or the intrusion condition removed after the time-out for the system to exit alarm mode.

Door Ajar Switches

The CTD system uses the door ajar switches in the door jambs as one method to activate the alarm. The BCM monitors all door ajar switches via a discrete input from each door ajar switch, including the rear compartment. If the BCM receives a ground signal from a door ajar switch when the CTD system is armed, the BCM activates the alarm.

Inputs

The BCM monitors the following inputs:

- Driver and passenger door ajar switches
- Rear compartment ajar switch
- Transmitter LOCK/UNLOCK buttons, internal function of the BCM
- Passlock(tm) Status-the BCM uses the passlock(tm) status for disarming the system or silencing and alarm when the correct key is used.

Outputs

The BCM controls the following:

- The horn relay
- The exterior lights

VEHICLE THEFT DETERRENT (VTD) DESCRIPTION AND OPERATION

Passlock(tm) System

The theft deterrent system has been incorporated into the body control module (BCM). The theft deterrent is provided in order to prevent the vehicle operation if the correct key is not used in order to start the vehicle. The ignition key turns the lock cylinder. The cylinder rotation produces an analog voltage code in the Passlock(tm) sensor. This voltage code is received by the BCM. The BCM compares the voltage code to the previously learned voltage code. If the codes match, a class 2 message is sent from the BCM to the powertrain control module (PCM)/vehicle control module (VCM). The message enables the fuel injectors.

The design of the Passlock(tm) system is to prevent vehicle theft by disabling the engine unless the ignition lock cylinder rotates properly by engaging the correct ignition key. The system is similar in concept to the PASS-Key(R) system. However, the Passlock(tm) system eliminates the need for a key mounted resistor pellet. The components of the Passlock(tm) system are as follows:

- The ignition lock cylinder
- The ignition switch
- The Passlock(tm) sensor
- The Body control module (BCM)
- The security telltale
- The vehicle/powertrain control module (VCM/PCM)

Ignition Lock Cylinder and Housing

The ignition lock cylinder is located at the upper right side of the steering column. The Passlock(tm) sensor is in the steering column. The Passlock(tm) sensor is separate from the key and lock cylinder. The key and the lock cylinder work together in order to determine if the proper ignition key was used to start the vehicle.

In the event of an open Class 2 serial data line between the BCM and the VCM/PCM, the vehicle will become fail-enabled if the VCM/PCM has already received the password from the BCM for that ignition cycle, the engine is running. In this event, the following conditions occur:

- The security telltale will be ON continuously.
- The VCM/PCM will become fail-enabled for future ignition cycles.

If a failure in the Class 2 serial data line occurs before the ignition cycle, when the VCM/PCM is not fail-enabled, the following conditions occur:

- The VCM/PCM will never receive a valid password in order to enable the fuel injectors.

- The vehicle will not start.

Ignition Switch

The lock cylinder and the visible key insert portion of the ignition switch are located at the upper right side of the steering column. The electrical switching portion of the assembly is separate from the key and lock cylinder. The electrical switch portion is hidden inside the steering column. The electrical switch portion and the key and lock cylinder synchronize and work in conjunction through the action of the mechanical assembly between the 2 parts.

Passlock(tm) Sensor

The Passlock(tm) sensor is inside the ignition cylinder lock housing. The Passlock(tm) sensor contains 2 hall effect sensors. The tamper hall effect sensor is on the top. The security hall effect sensor is under the tamper hall effect sensor. Both of the hall effect sensors monitor the magnet of the lock cylinder through an opening. The tamper hall effect sensor is physically placed on top of the security hall effect sensor. This arrangement enables the tamper hall effect sensor to engage first if an intruder attempts to bypass the Passlock(tm) sensor by placing a large magnet around that area of the steering column. There is a tamper resistor inside the Passlock (tm) sensor in order to help prevent tamper to the system. Passlock(tm) equipped vehicles have a selection of 10 different security resistors ranging from 0.5K ohms up to 13.6K ohms. Installing one of the security resistors inside the Passlock(tm) sensor will generate a unique Passlock(tm) code. All 10 combinations of the Passlock (tm) sensor have the same part number. However, you cannot simply replace the Passlock(tm) sensor and expect the system to operate properly. Always start by performing the Diagnostic System Check first and following the instructions.

Body Control Module

The Body Control Module (BCM) contains the theft deterrent system logic. The BCM reads the Passlock(tm) data from the Passlock(tm) sensor. If the Passlock(tm) data is correct, the BCM will pass theft. The BCM will then transmit the fuel continue password to the VCM/PCM.

During the tamper mode the vehicle may start. The vehicle will then stall. If the BCM receives the wrong Passlock(tm) data, the VTD will immediately go into the tamper mode. The tamper mode will lock-out the vehicle fuel injectors for 10 minutes. The SECURITY indicator will flash while the VTD is in the tamper mode.

If the Passlock(tm) sensor sends a correct password to the BCM when the ignition is in the ON position, the BCM will send a fuel enable signal to the VCM/PCM. The VCM/PCM will not disable the fuel due to any BCM message for the remainder of the ignition cycle.

SECURITY Telltale

The SECURITY telltale appears on the message center inside the instrument cluster. If the SECURITY telltale flashes or if the SECURITY telltale lights continuously during the vehicle operation, refer to the system diagnosis.

Vehicle/Powertrain Control Module

The VCM/PCM communicates with the BCM over the Class 2 serial data line. When the BCM determines a no start condition, it sends a Class 2 serial data password to the VCM/PCM in order to disable the fuel injection system. If the BCM receives the expected voltage from the Passlock(tm) sensor, the BCM sends a class 2 serial data password to the VCM/PCM in order to enable the fuel injection system. The VCM/PCM then allows the vehicle to start correctly. If the Class 2 serial data password from the BCM to the VCM/PCM is not within the Vehicle Security Status Message, the fuel injectors will shut OFF during a start attempt. The SECURITY telltale will be illuminated for 10 minutes. If the VCM/PCM does not receive the same password from the BCM as the last learned one, the vehicle will start and then stalls due to the Fuel Lockout.

Fuel Lockout Cycle

The Passlock(tm) system has a lockout cycle of approximately 10 minutes. Once the vehicle is in the lockout cycle, the vehicle remains in the lockout cycle for 10 minutes, even if the ignition switch is turned from the RUN position to the OFF position.

The Passlock(tm) system uses the lockout cycle in order to synchronize all of the Passlock(tm) components when any Passlock(tm) related part is changed. The Passlock(tm) system requires 3 consecutive lockout cycles in order to complete the 30 minute learn procedure for a changed component.

Changing the Passlock(tm) Components

The design of the Passlock(tm) system is to prevent theft even if the various theft deterrent parts change. The parts that can no longer be changed without the possibility of going into a tamper mode are:

- The Passlock(tm) sensor
- The BCM
- The VCM/PCM

If you replace any of these parts the vehicle may start and stall for 10 minutes. This is the long tamper mode. If this occurs, the system must go through a long tamper mode cycle. During this time the SECURITY telltale will be flashing for the full 10 minutes and the DTC B3031 will be set. The BCM and the VCM/PCM require the full 10 minutes in order to complete a learn cycle. The ignition switch must remain in the RUN position until the SECURITY telltale stops flashing. You will need to repeat the cycle if the ignition switch does not remain in the RUN position. When replacing any of the above parts it is recommended to perform the **Programming Theft Deterrent System Components** procedure.

The design of the Passlock(tm) system is to prevent the vehicle operation if the proper ignition key is not used in order to start the vehicle. The mechanical key, in normal operation, will turn the ignition lock cylinder. The Passlock(tm) sensor monitoring the position of the lock cylinder will relay the Passlock(tm) data to the body control module (BCM). The BCM will determine the validity of the Passlock(tm) data. The BCM will send a fuel continue password to the vehicle/powertrain control module (VCM/PCM). When the VCM/PCM receives the correct password the VCM/PCM allows the fuel injectors to operate normally. The Passlock(tm) system requires the VCM/PCM and the BCM to communicate the various functions in order to operate. These functions transmit over the class 2 serial data line. For an explanation of the class 2 serial data description and operation, refer to **Data Link Communications Description and Operation** in Data Link Communications.